

Assembly/Mounting Instructions Onyx Permanently Tensioned Projection Screen by Draper

Caution

- ① Read instructions through completely before proceeding.
- ② Follow instructions carefully. Installation contrary to instructions invalidates warranty.
- ③ Screen should be accessible for complete removal should fabric become damaged or should other service be required.
- ④ Screen should be installed level (using a carpenter's level).
- ⑤ Nothing should be fastened to screen frame or viewing surface.
- ⑥ Make sure you have received all parts (see parts list below and exploded diagram on page 2).
- ⑦ Tools Required: Medium (#2) Phillips screwdriver (6" or greater shaft length suggested). Optional tools: Flat blade screwdriver or small putty knife.

NOTE: Screen has been thoroughly inspected and tested at factory and found to be operating properly prior to shipment.

Onyx—Hardware and Parts List

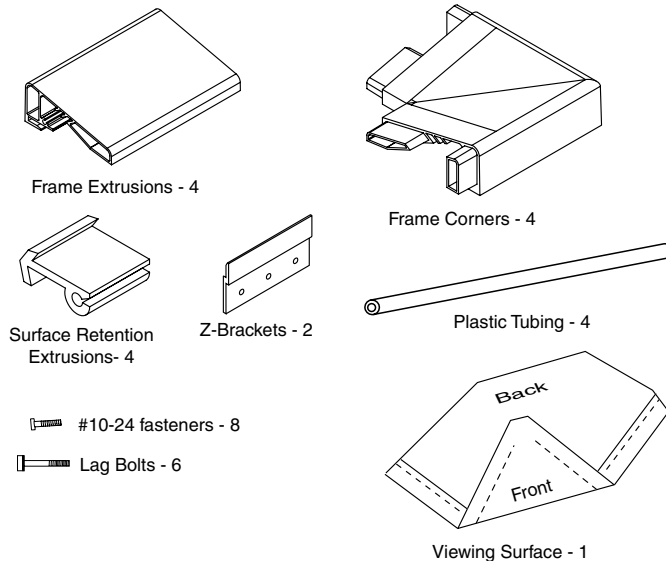

Frame Preparation

- ① Clean area and place frame assembly pieces face down. Insert plastic corner pieces into ends of aluminum frame extrusions as indicated in Figures 1 through 4. Secure each corner to each frame extrusion by threading one #10-24 fastener through hole in plastic corner and into rounded slot in aluminum frame extrusion.

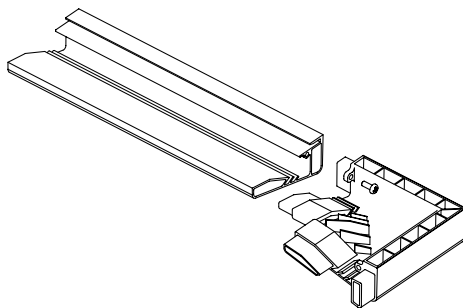

Figure 1

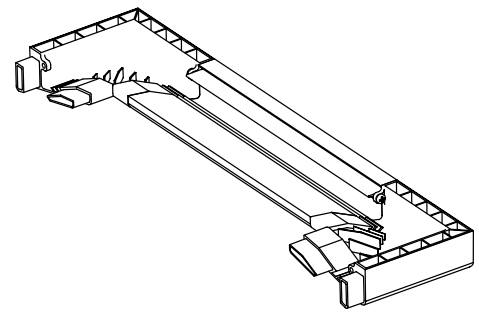

Figure 2

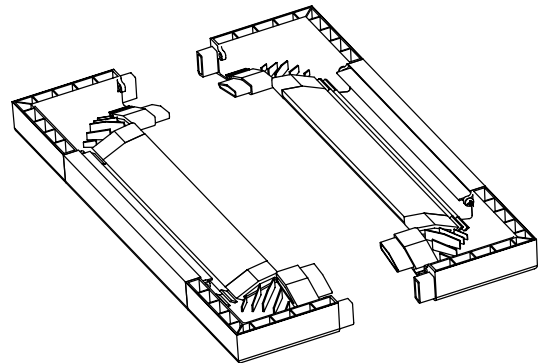

Figure 3

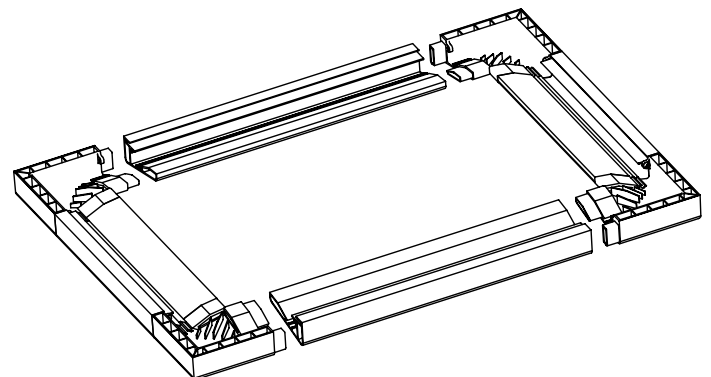

Figure 4

- ② Secure corner pieces to aluminum frame extrusions with four (4) remaining fasteners. Check to verify that all four (4) plastic corners are secure to aluminum frame extrusion lengths and all eight (8) fasteners are tight (see Fig. 5).

Please Note: It is not necessary to over-tighten fasteners.

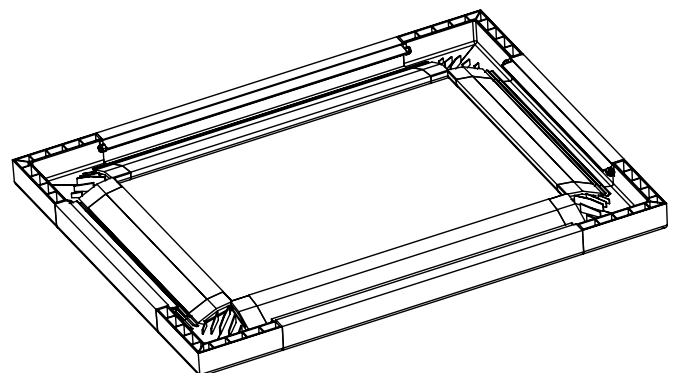

Figure 5

DRAPER

411 S. Pearl St., Spiceland, IN 47385 USA ■ 765-987-7999 ■ fax 765-987-7142
e-mail draper@draperinc.com ■ www.draperinc.com

Copyright © 2004 Draper Inc.

Form Onyx_Inst04

Printed in U.S.A.

(Continued on Page 2)

If you encounter any difficulties installing or servicing your Onyx screen, call your dealer or Draper, Inc., Spiceland, Indiana, (765) 987-7999; draper@draperinc.com.

Surface Preparation

- ① Move frame assembly out of the way, unroll viewing surface and place on smooth/clean surface. (Orient viewing surface so that folded side of hem is visible.)
- ② Insert plastic tubing inside pocket formed by hem on all 4 edges of viewing surface (see Fig. 6).

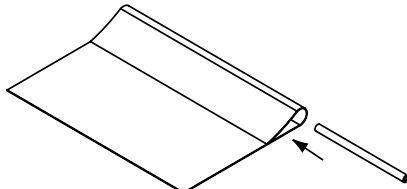

Figure 6

- ③ **Carefully** slide surface retention extrusion (rounded edge visible) along hem and onto surface on all 4 edges of fabric (see Fig. 7). **Caution: Do not allow fabric to snag on end of extrusion. If the screen fabric is not parallel with the surface retention extrusion, then it may slit and tear during installation.**

Please Note: To make this step easier, pinch the end of the pocket closed before sliding it into the surface retention extrusion.

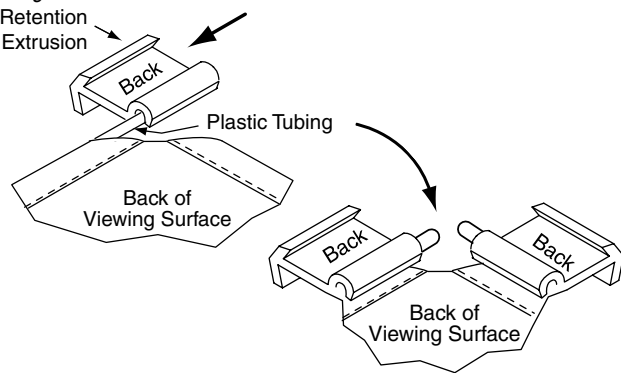

Figure 7

- ④ Surface retention extrusion should extend beyond edge of viewing surface equally at both ends.
- ⑤ Verify that all surface retention extrusions are installed with rounded edge visible and are centered on surface material.

Surface to Frame Assembly

- ① Return frame onto clean surface, face down, and drape completed surface assembly over completed frame profile with rounded edge of surface retention extrusion visible.
- ② Insert any side of surface to notch #1 on corresponding side of frame extrusion (see Fig. 8).

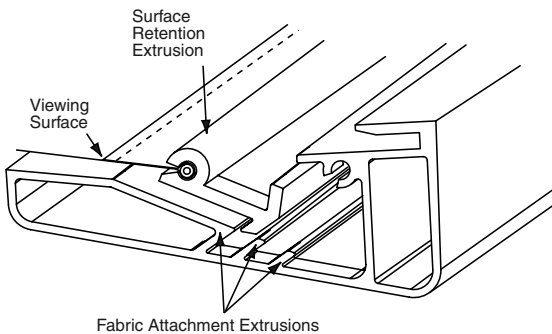

Figure 8

- ③ Insert opposite side of surface to notch #1 of frame extrusion.
- ④ Repeat steps 2-3 with remaining edges of surface.
- ⑤ Ensure surface retention extrusions are centered lengthwise in tension slots on all 4 edges of surface.
- ⑥ If additional tension is desired or required over time, adjust surface one edge at a time to tension notch #2.

Please Note: It is not necessary to adjust more than one edge at a time to increase surface tension.

Mounting Screen to Wall

- ① Determine height at which screen is to be mounted.
Please Note: Top edge of screen frame will be located 1.5" above mounting bracket hole centerline when mounted to wall.
- ② Mark hole centerline so that both Z-brackets can be mounted parallel and at equal height.
- ③ Install Z-brackets so that the outermost edges are safely within the overall length of the aluminum frame extrusion to allow for minor horizontal screen adjustments.
- ④ Position screen slightly above Z-brackets on wall (see Fig. 9).

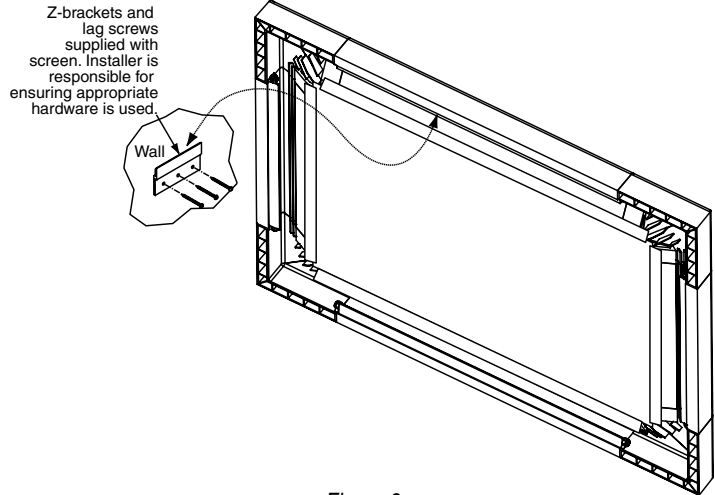
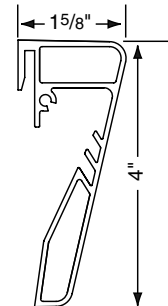

Figure 9

- ⑤ Lower screen until it engages over Z-brackets. Center screen horizontally on brackets as necessary.
Please Note: Make sure screen is installed level.

Onyx Frame—Side Detail*



*Viewing surface is approximately 1/4" from wall.

Onyx (Exploded Rear View)

