

Installation/Operating Instructions

220V Ultimate Access Electric Projection Screen by Draper

These Installation/Operating Instructions are available in the official language of the country where you purchase the product. Please contact your distributor to request a copy.

Vous pourriez demander les instructions d'installation et d'opération traduites dans la langue officielle du pays où vous achetez le produit. Veuillez demander à votre distributeur.

Die Gebrauchsanweisung für Installation und Konstruktion sind in der offiziellen Sprache des Landes, indem Sie das Produkt gekauft haben, vorhanden. Fragen Sie die jeweilige Verkaufs-Abteilung.

Caution

- 1 Read instructions through completely before proceeding.
- 2 Follow instructions carefully. Installation contrary to instructions invalidates warranty.
- 3 Entire bottom of screen case should be unobstructed to permit access to bottom panel for electrical connections or servicing.
- 4 Screen should be installed level (using a carpenter's level).
- 5 Nothing should be fastened to screen dowel or viewing surface.
- 6 Operating switch(es) and mounting brackets are packed separately in screen carton. Do not discard with packing material.
- 7 Screen operates on 220 V., 50 Hz. current.

NOTE: Screen has been thoroughly inspected and tested at factory and found to be operating properly prior to shipment.

Hanging Screen

When locating viewing surface and checking clearance for screen's operation, remember surface is centered in the length of the case.

Screen is normally recessed above ceiling and may be installed in a variety of ways. See typical installations detailed on page 3. Regardless of mounting method used, the following points apply:

- 1 Mounting brackets are packed separately in carton. Engage each bracket with top of housing as shown below and tighten set screws. A bracket should be within 46 cm from each end of screen case. Brackets can be removed and case mounted with lag screws through top of case (holes drilled on site).
- 2 Screen should be positively and securely supported so that vibration or even abusive pulling on viewing surface will not weaken installation.
- 3 Installer must insure that fasteners used are of adequate strength and suitable for the mounting surface chosen.
- 4 Entire bottom of case must be readily accessible after installation is complete.
- 5 The bottom access panel, trap door, and lower edge of the case are joined with continuous hinge joints and must operate freely. Front and back of case must be straight—not forced to warp or bow. Hinge joints must be free of mastic or paint build up, and trapdoor and access panel must be unobstructed by ceiling tiles.
- 6 If case is painted on location, removal of roller/fabric assembly is recommended prior to painting. If not removed, slots on bottom of case should be shielded to protect viewing surface from paint splatters or overspray.
- 7 Do not seal unit in ceiling until electrical connections have been made and screen has been operated successfully.

Electrical Connections

Screen operates on 220 V., 50 Hz. current.

Junction box is located just above the bottom access panel at left end of screen.

Open the access panel/trap door for access to the junction box cover. (See bottom access panel/trap door opening and closing instructions below).

Remove two (2) hex head screws that secure the cover to the junction box to expose the terminal strip per wiring diagram on page 4.

If optional low voltage control or video interface control is specified and factory installed, please refer to wiring diagram on page 4.

Screen is shipped with internal wiring complete and control switch(es) fully boxed. Wire to connect screen to switch(es) and switch(es) to power supply should be furnished by installer. Connections should be made in accordance with attached wiring diagram, and wiring should comply with national and local electrical codes.

All operating switches should be "off" before power is connected.

Bottom Access Panel/Trap Door Opening & Closing

After screen case has been mounted, remove the dowel shipping brackets from dowel if provided. **A spring latch at each end of the trap door holds this assembly closed. In some screens there will also be a spring latch near the center of the case.** To gain access to inside of screen case, disengage spring latch at each end of the case (and near the center of the case, if applicable) by sliding the latch lever towards the center of screen case, then pull down slightly on the trap door assembly. The latch levers are somewhat concealed from view. Locate these with the trap door open by feeling for the vertical latch lever above the door about 8 cm from case endcaps and near the center of the case.

The assembly will swing down, opening about 135°. Pivot the prop arms at each end of the trap door assembly towards the ends of screen case. Prop arms engage with a hole in each endcap to hold the trap door assembly fully open. To close the trap door assembly disengage prop arms from endcaps and pivot these over the access panel. Swing the trap door assembly upward, stopping just before the latch levers hit the bottom flanges of the endcaps (and center of case where appropriate). Pull levers of latches towards center of screen case to allow the trap door assembly to be pivoted to its closed position. Make sure that the spring latch levers engage fully with case endcaps (and center of case where appropriate).

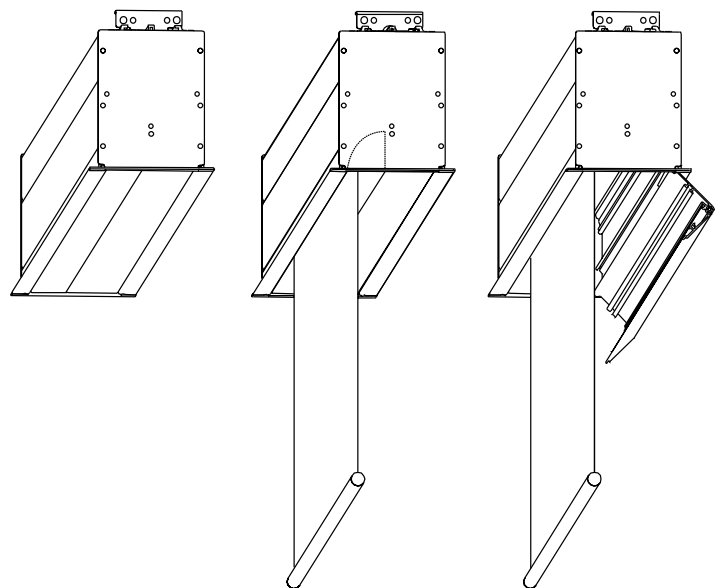

If you encounter any difficulties installing or servicing your Ultimate Access screen, call your dealer or Draper, Inc., in Spiceland, Indiana, 765/987-7999; fax 765/987-1689; or e-mail draper@draperinc.com.

DRAPER

411 S. Pearl St., Spiceland, IN 47385 USA ■ 765-987-7999 ■ fax 765-987-1689
e-mail draper@draperinc.com ■ www.draperinc.com

Copyright © 2003 Draper, Inc. Form UltimateAccess220v_Inst03 Printed in U.S.A.

Motorized Roller/Fabric Installation

The bottom access panel/trap door assembly must be opened and placed in fully opened position first.

The motor end mounting bracket has a metal bracket with snap ring for accepting motor head. Back out the four set screws in bracket until they are flush with top side of bracket.

To engage the motor end bracket flange above the two channels in the top of the screen housing, rotate the bracket approximately 45° counterclockwise to allow the top surface of the motor bracket to rest flat against the top inside of the housing. Rotating the bracket clockwise until it is engaged with the channels, slide it along the length of the housing against the electrical junction box.

Engage the idler end bracket (rectangular mounting pad) in the same manner as the motor end bracket and slide it toward the opposite end of the screen housing. Do not tighten the set screws on the brackets until the roller/fabric assembly is installed, and centered in the case.

Locate the black washer and retaining clip.

Note: This will require two people to perform safely. Raise the roller/fabric assembly up into the screen housing and engage the head of the motor completely into the motor mounting bracket, making sure the snap ring engages with the motor and that the limit switch adjusting knobs are visible from the bottom of the screen housing.

While supporting the idler end of the roller, slide the idler end mounting bracket toward the roller. Insert the roller pin into the nylon bushing on the idler end mounting bracket.

The roller idler pin needs to go through the idler bracket far enough to allow the washer and retaining clip to be reinstalled on the pin.

Failure to replace the washer and retaining clip as shown could result in the separation of the roller from the brackets.

The roller/fabric assembly and roller brackets may need to be slid left or right in mounting channel of case to center fabric within screen case.

Securely tighten the set screws on the roller mounting brackets.

Connect the electrical plug from the motor to the mating socket on the junction box.

Close the bottom access panel/trap door as previously described.

Motorized Roller/Fabric Removal

Reverse the instructions above, under “Motorized Roller/Fabric Installation,” for removal of the unit.

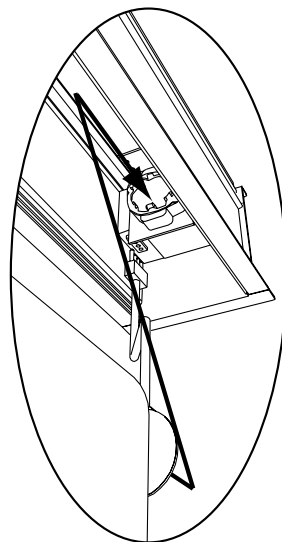
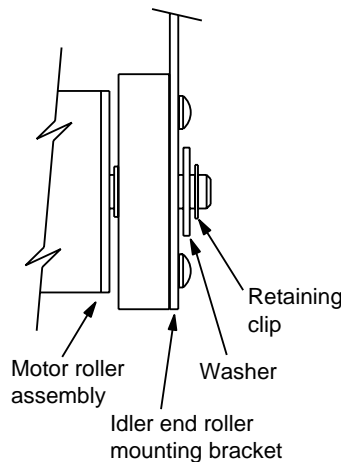

Operation

When screen is first operated, **be cautious!** Cycle unit down and up several times to confirm satisfactory operation.

220V SINGLE STATION CONTROL—3-position UP-OFF-DOWN switch permits operation to be stopped at any point. Factory adjusted limit switches automatically stop screen when fully down or fully up.

220V MULTIPLE STATION CONTROL—(Not CE approved) Switches are similar in appearance to 220V Single Station Control. Screen stops when switch is released and may be restarted in either direction. Factory adjusted limit switches stop screen automatically when fully up or fully down.

24V MULTIPLE STATION CONTROL—Three-button UP-STOP-DOWN switches stop at any point desired, operate in any sequence. Factory adjusted limit switches automatically stop screen when fully up or down.

220V & 12V VIDEO INTERFACE CONTROL—(Not CE Approved). Allows screen to be controlled by a trigger signal—when signal comes on, screen descends automatically. Two versions: Model VIC220 integrates screen operation with a DRAPER video projector lift or a video projector or tuner with a 220V switched outlet. Model VIC12 interfaces with 12V switched outlet. Both available with override switch (VIC-OS), permitting independent operation. VIC-OS not available with factory installed VIC220 & VIC12.

KEY OPERATED SWITCHING—Two kinds of key-operated switches are optionally available with this unit.

- ① The key-operated power supply switch controls power to screen and switches. When it is “off”, the switches will not operate screen. Key may be removed from the switch in either “on” or “off” position.
- ② A three-position key switch permits screen to be operated directly by key. In this case, the screen’s operator must always have a key.

Adjustments

Screen has been factory set and should not normally require further adjustment. However, if you desire to change the “up” and “down” stopping positions, refer to drawing below, determine whether you need to adjust the white or yellow socket, and proceed as follows:

CAUTION: Be sure all switches are in “off” position before adjusting limit switches. Always be prepared to shut screen off manually when new adjustment is being tested. Screen may be severely damaged if viewing surface is allowed to run too far up or too far down.

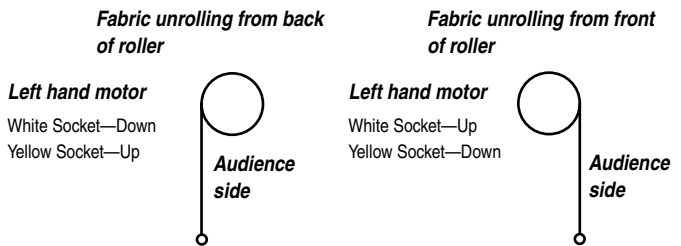

ADJUSTING WHITE SOCKET—White socket is located on motor end of screen roller and is accessible to a small flat screwdriver or a 4 mm (5/32”) hex key. Turning socket counterclockwise will allow the roller to run farther up or down (as appropriate). Turning it clockwise will shorten operation, causing screen to stop sooner. One full revolution of the socket will alter the stopping position of the viewing surface by approximately 32 mm.

ADJUSTING YELLOW SOCKET—Yellow socket is located on the motor end of screen roller and is accessible to a small flat screwdriver or a 4 mm (5/32”) hex key. Turning the socket counterclockwise will allow the roller to run farther up or down (as appropriate). Turning it clockwise will cause the roller to stop sooner. One full revolution of the socket will alter the stopping position of the viewing surface by approximately 32 mm.

AT NO TIME SHOULD VIEWING SURFACE BE UNROLLED ENOUGH TO EXPOSE ANY PART OF SCREEN ROLLER.

Tab-Tension Adjustment Procedure for Ultimate Access/Series V

- ① Determine which side requires adjustment.
 - ② Secure dowel with one hand.
- Caution: Do not touch or bend surface.**
- ③ Using Philips-head screwdriver, depress spring-loaded adjustment screw (see drawing) and slowly turn clockwise to tighten tension, or counterclockwise to loosen tension. The screw adjusts in ¼ turn increments. Adjust only **one increment** (¼ turn).
 - ④ If problem is not corrected, leave screen in position for 24 hours to allow surface material to stretch into position.
 - ⑤ If problem still is not corrected, repeat steps 2 and 3.

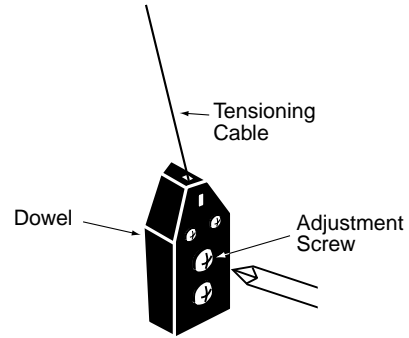

Case Dimensions

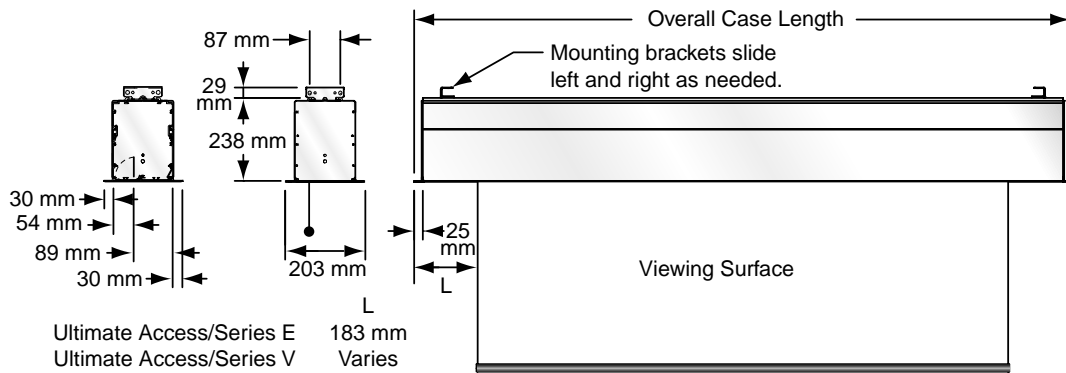

Mounting Options

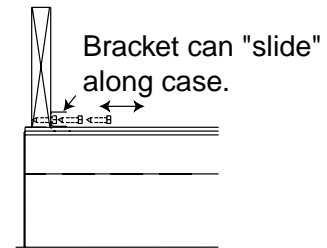
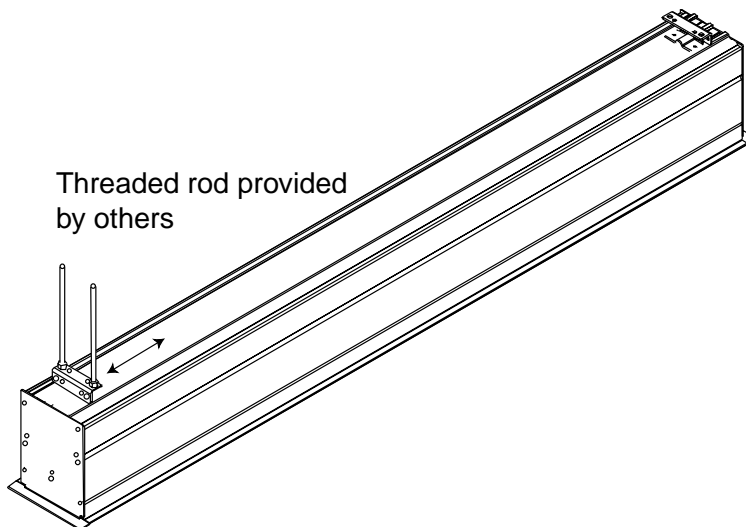

OPTION 1: Threaded Rod through top of mounting brackets. NOTE: A mounting bracket should be positioned within 46 cm from each end of case.

OPTION 2: Lagged through side of mounting bracket. Brackets can “slide” along the length of the case.

Brackets can “slide” along the length of the case.

OPTION 3: Lagged through top of screen case. Remove mounting brackets from case and drill 11 mm diameter holes through top of case.

OPTION 4: In a grid ceiling, with wire through top of mounting brackets.

Wiring Diagrams

Single Station Control
CE Approved

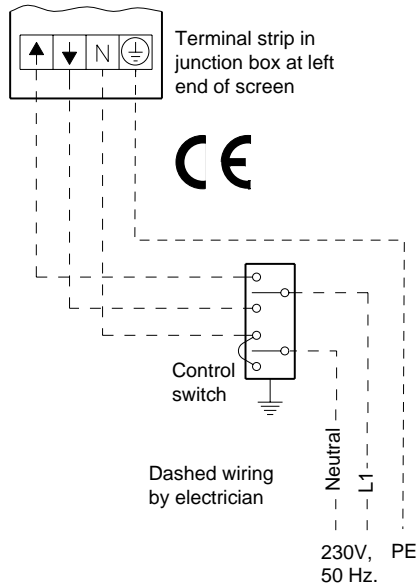

Multiple Station Control
Not CE Approved

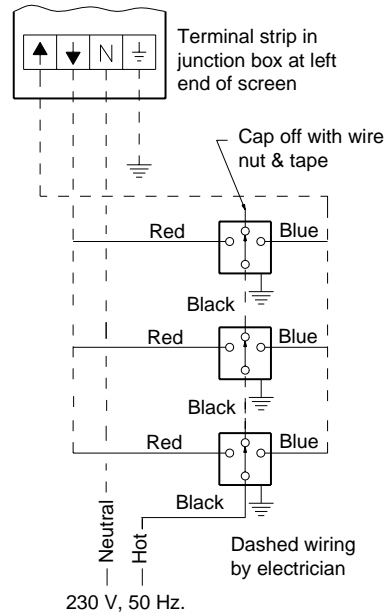

Low Voltage (& Wireless) Control Wiring Diagram
CE Approved

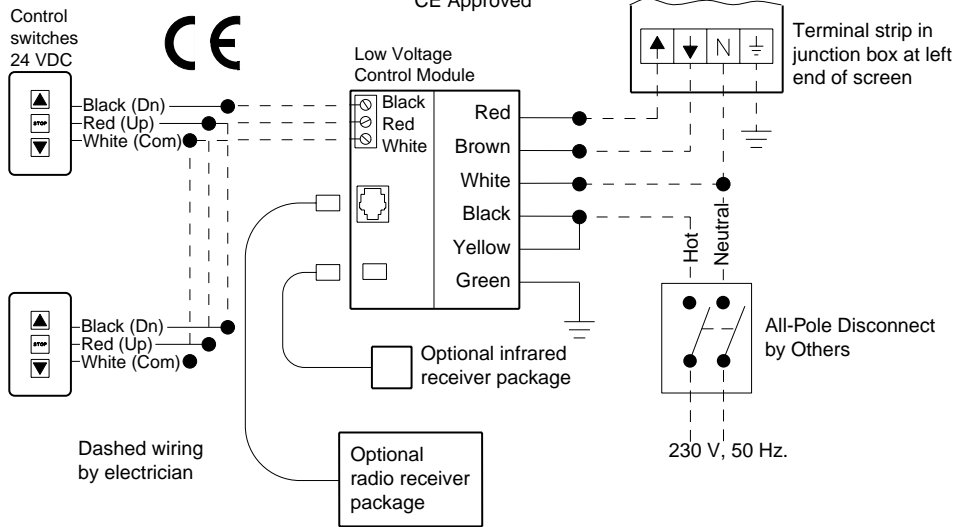

Wiring Diagrams for Optional Built-in Controls*

Not CE Approved

Built-in Low Voltage Control

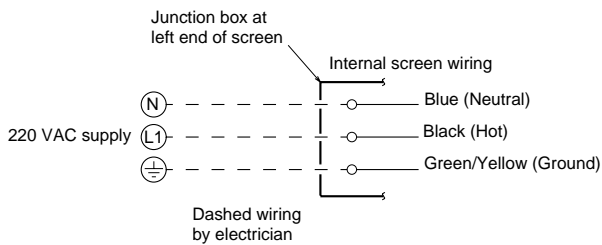

Built-in Video Interface Control

