

## 220 Volt Installation/Operating Instructions

# Access/MultiView Electric Projection Screen & Masking System by Draper

These Installation/Operating Instructions are available in the official language of the country where you purchase the product. Please contact your distributor to request a copy.

*Vous pourriez demander les instructions d'installation et d'opération traduites dans la langue officielle du pays où vous achetez le produit. Veuillez demander à votre distributeur.*

*Die Gebrauchsanweisung für Installation und Konstruktion sind in der offiziellen Sprache des Landes, indem Sie das Produkt gekauft haben, vorhanden. Fragen Sie die jeweilige Verkaufs-Abteilung.*

### Caution

- ① Read instructions through completely before proceeding.
- ② Follow instructions carefully. Installation contrary to instructions invalidates warranty.
- ③ Entire bottom of screen case should be unobstructed to permit access to bottom panel for making electrical connections or servicing.
- ④ Screen should be installed level (using a carpenter's level).
- ⑤ Nothing should be fastened to screen dowel, viewing surface, or masking.
- ⑥ Operating switches packed separately in screen carton. Do not discard with packing material.
- ⑦ Screen operates on 220v, 50 Hz., 1 ph current.

**NOTE:** Screen has been thoroughly inspected and tested at factory and found to be operating properly prior to shipment.

### Hanging Screen

When locating viewing surface and checking clearance for screen operation, remember surface is centered in the length of the case. Regardless of mounting method used, the following points apply:

- ① Mounting brackets are packed separately in carton. Engage each bracket with top of housing as shown below and tighten set screws. A bracket should be within 46 cm of each end of screen case. Brackets can be removed and case mounted with lag screws through top of case (holes drilled on site).
- ② Screen should be positively and securely supported so that vibration or even abusive pulling on viewing surface or masking will not weaken installation.
- ③ Installer must insure that fasteners used are of adequate strength and suitable for the mounting surface chosen. Supporting hardware (chains, cables, rods, etc.) must be essentially vertical.
- ④ Entire bottom of case must be readily accessible after installation is complete.

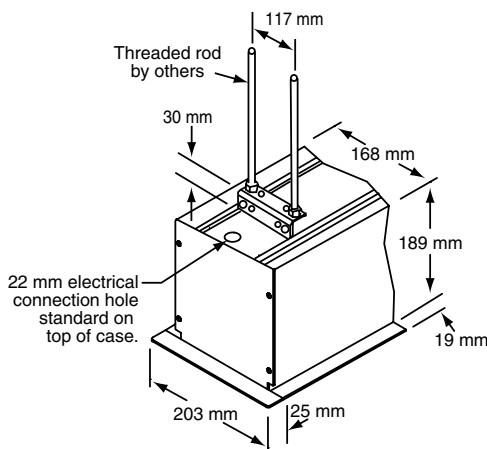

- ⑤ Front, back and top of case must be straight—not forced to warp or bow.
- ⑥ If case is painted on location, removal of roller/fabric assembly is recommended prior to painting. If not removed, slot on bottom of case should be shielded to protect viewing surface from paint splatters or overspray.
- ⑦ Do not seal unit in ceiling until electrical connections have been made and screen has been operated successfully.

### Electrical Connections

Screen operates on 220v, 50 Hz., 1 ph current.

All connections are made in the junction box located just above the bottom access panel at left end of screen. Remove the bottom access panel for access to the junction box cover. (See Bottom Access Panel Removal instructions below).

Remove four (4) hex head screws that secure the cover to the junction box to expose two sets of red, black, and white pigtail leads and the green ground wire per wiring diagram on page 4.

If optional low voltage control or video interface control is specified and factory installed for either motor, please refer to wiring diagram on page 3.

Screen is shipped with internal wiring complete and control switch(es) fully boxed. Wire to connect screen to switch(es) and switch(es) to power supply should be furnished by installer. Connections should be made in accordance with attached wiring diagram, and wiring should comply with national and local electrical codes.

**All operating switches should be "off" before power is connected.**

### Bottom Access Panel Installation/Removal

Bottom access panel hooks over the lower inside edge of the screen housing and then is pivoted downward until the engagement brackets on each end of the bottom panel click into place with the ball detents on each endcap. Make sure bottom access panel clicks in place at each end of its length.

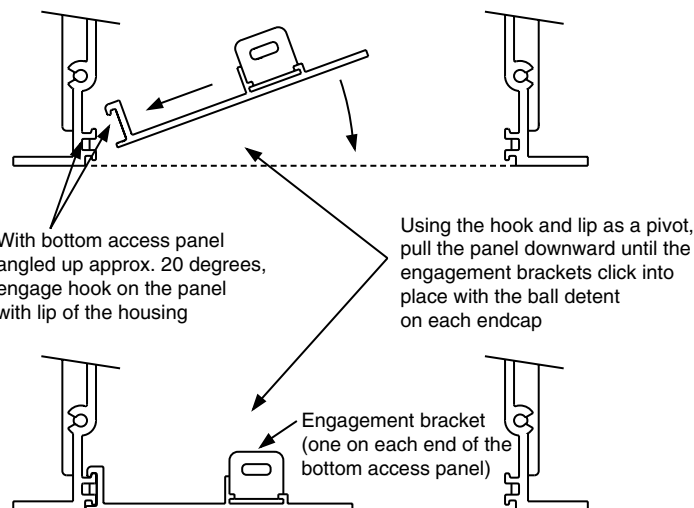

Remove bottom access panel by pushing up at each corner of panel adjacent to slot in bottom of the housing. With bottom access panel angled up approximately at 20° it can be lifted off of the lip of the housing and then lowered out of the housing completely.

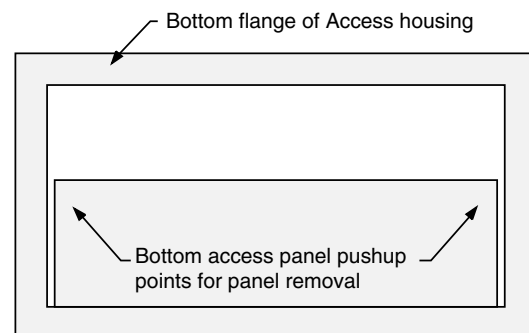

Access case as seen from below

# DRAPER

411 S. Pearl St., Spiceland, IN 47385 USA ■ 765-987-7999 ■ fax 765-987-1689

e-mail draper@draperinc.com ■ www.draperinc.com

Copyright © 2002 Draper Inc.

Form AccessMultiView220v\_Inst02

Printed in U.S.A.

### Motorized Roller/Fabric Installation

The bottom access panel must be removed first. The Access/MultiView has two roller/fabric assemblies. The one equipped with a complete projection screen fabric is installed first, higher in the brackets, and connects to the left-hand junction box. The second roller has black masking strips at the sides and no fabric in the middle: it installs lower in the brackets and connects to the right-hand junction box.

The motor end mounting brackets have steel mounting rings with prongs that engage with motor head.

To engage the motor end bracket flange above the two channels in the top of the screen housing, rotate the bracket approximately 45° counterclockwise to allow the top surface of the motor bracket to rest flat against the top inside of the housing. Rotating the bracket clockwise until it is engaged with the channels, slide it along the length of the housing toward the electrical junction box at left end of case.

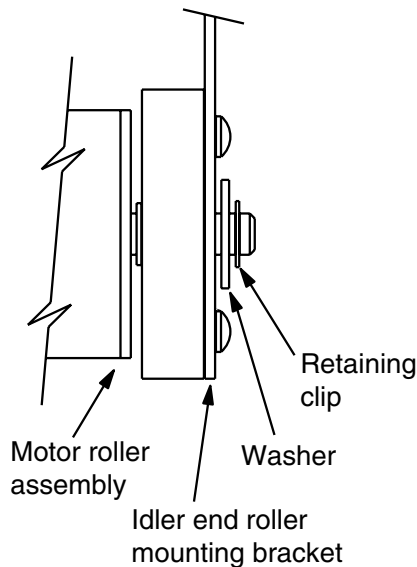

Engage the idler end bracket (rectangular mounting pad) in the same manner as the motor end bracket and slide it toward the opposite end of the screen housing. Do not tighten the set screws on this bracket until the roller/fabric assembly is installed.

Locate the viewing surface roller/fabric assembly and remove the retaining clip and flat steel washer from the idler end pin.

**(NOTE: This will require two people to perform safely.)** Raise the viewing surface roller/fabric assembly up into the screen housing and engage the head of the motor completely into the motor mounting bracket. The steel clip on the motor mounting ring must snap into the groove on the motor. Once this is done the clip must be manually pulled down away from the mounting ring to disengage motor. Make sure the limit switch adjustment knobs are visible from bottom of housing.

While supporting the idler end of the roller, slide the idler end mounting bracket toward the roller. Insert the roller pin into the nylon bushing on the idler end mounting bracket.

The roller idler pin needs to go through the idler bracket far enough to allow the steel washer and retaining clip to be reinstalled on the pin. Failure to replace the washer and retaining clip as shown could result in the separation of the roller from the brackets.

The fabric/roller assembly and brackets will need to be moved left or right until centered in case. Tighten two set screws on each roller mounting bracket using 1/8" hex key.

Locate the masking roller assembly and remove the retaining clip from motor stud and remove retaining clip and washer from idler pin.

Raise masking roller up into screen housing making sure motor is on the right (as viewed by audience). Engage the motor stud inside square bushing.

Engage the idler pin all the way through the round bushing on left roller mounting bracket. Place washer over pin and fasten retaining clip in the groove of idler pin.

Connect the electrical plugs from the motors to the mating sockets on the junction boxes.

Reinstall the bottom access panel as previously described.

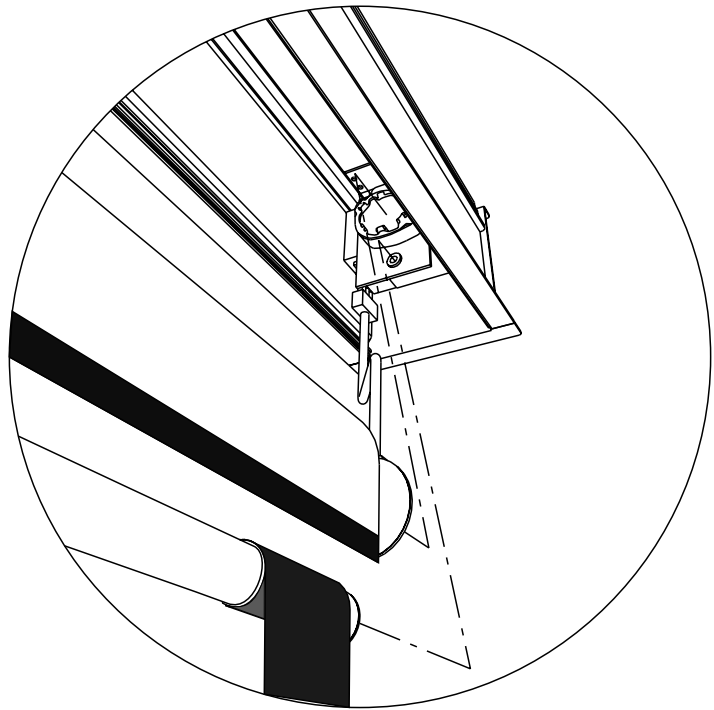

### Motorized Roller/Fabric Removal

Reverse the instructions above under "Motorized Roller/Fabric Installation" for removal of the unit.

### Operation

When screen and masking are first operated, **be cautious!** Cycle unit down and up several times to confirm satisfactory operation. Factory adjusted limit switches should automatically stop screen or masking when fully down or fully up. Separate controls operate screen and masking motors, unless the Access/MultiView Control is used.

**220V SINGLE STATION CONTROL (2 standard)**—3-position UP-OFF-OWN switches permit operation to be stopped at any point.

**220V MULTIPLE STATION CONTROL**—(Not CE Approved) Switches are similar in appearance to 220V Single Station Control. Screen stops when switch is released and may be restarted in either direction.

**ACCESS/MULTIVIEW CONTROL**—This 24V control permits both motors to be operated from a single switch, which is equipped with two sets of UP-OFF-DOWN buttons.

**24V MULTIPLE STATION CONTROL**—Separate three-button UP-STOP-DOWN switches for each motor, stop at any point desired, operate in any sequence.

**220V & 12V VIDEO INTERFACE CONTROL**—(Not CE Approved) Allows screen to be controlled by a trigger signal—when the signal comes on, the screen descends automatically. Two versions: Model VIC220 integrates screen operation with a DRAPER video projector lift or a video projector or tuner with a 220V switched outlet. Model VIC12 interfaces with a 12V switched outlet. Both available with an override switch (VIC-OS), permitting independent operation. VIC-OS not available with factory installed VIC220 & VIC12.

**KEY OPERATED SWITCHING**—(Not CE Approved) Two kinds of key-operated switches are optionally available with this unit.

- ① The key-operated power supply switch controls power to the screen and switches. When it is "off", the switches will not operate screen. Key may be removed from the switch in either "on" or "off" position.
- ② A three-position key switch permits the screen to be operated directly by key. In this case, the screen's operator must always have a key.

**Adjustments (Screen Motor)**

Screen has been factory set and should not normally require further adjustment. However, if you desire to change the “up” and “down” stopping positions, proceed as follows:

**CAUTION:** Be sure all switches are in “off” position before adjusting limit switches. Always be prepared to shut screen off manually when new adjustment is being tested. Screen may be severely damaged if surface is allowed to run too far up or too far down.

**“DOWN” LIMIT SWITCH**—Down stopping position can be adjusted by turning the white socket (located on the motor end of screen roller). Turning the socket counterclockwise will allow the roller to run farther down. Turning it clockwise will shorten operation, causing it to stop sooner. One full revolution of the socket will alter the stopping position of the viewing surface by approximately 32 mm.

**“UP” LIMIT SWITCH**—Up stopping position can be adjusted by turning the yellow socket (located on motor end of screen). Turning the socket counterclockwise will allow the roller to run farther up. Turning it clockwise will cause the roller to stop sooner. One full revolution of the socket will alter the stopping position of the viewing surface by approximately 32 mm.

AT NO TIME SHOULD SURFACE BE UNROLLED ENOUGH TO EXPOSE ANY PART OF SCREEN ROLLER.

**Adjustments (Masking Motor)**

Screen has been factory set and should not normally require further adjustment. However, if you desire to change the “up” and “down” stopping positions, proceed as follows:

**CAUTION:** Be sure all switches are in “off” position before adjusting limit switches. Always be prepared to shut screen off manually when new adjustment is being tested. Screen may be severely damaged if surface is allowed to run too far up or too far down.

**“DOWN” LIMIT SWITCH**—Down stopping position can be adjusted by turning knob #2 (on motor end of masking roller). Turning the knob counterclockwise will allow the roller to run farther down. Turning it clockwise will shorten operation, causing it to stop sooner.

**“UP” LIMIT SWITCH**—Up stopping position can be adjusted by turning knob #1 (on the motor end of masking roller). Turning the knob counterclockwise will allow the roller to run farther up. Turning it clockwise will cause the roller to stop sooner.

*If you encounter any difficulties installing or servicing your Access MultiView screen, call your dealer or Draper, Inc., Spiceland, Ind., (765) 987-7999; fax (765) 987-7142; or e-mail draper@draperinc.com.*

**Tab-Tension Adjustment Procedure for Access/Series V**

*Draper’s Tab-Tensioning System is factory-set, and under normal circumstances will not require field adjustment. If, however, you notice wrinkles, waves, or other indications that the tensioning cables need to be adjusted, follow the procedure below.*

- ① Determine which side requires adjustment.
  - ② Secure dowel with one hand.
- Caution: Do not touch or bend surface.**
- ③ Using Philips-head screwdriver, depress spring-loaded adjustment screw (see diagram at right) and slowly turn clockwise to tighten tension, or counterclockwise to loosen tension. The screw adjusts in ¼ turn increments. Adjust only **one increment** (¼ turn) at a time.
  - ④ If problem is not corrected, leave screen in position for 24 hours to allow surface material to stretch into position.
  - ⑤ If problem still is not corrected, repeat steps 2 and 3.

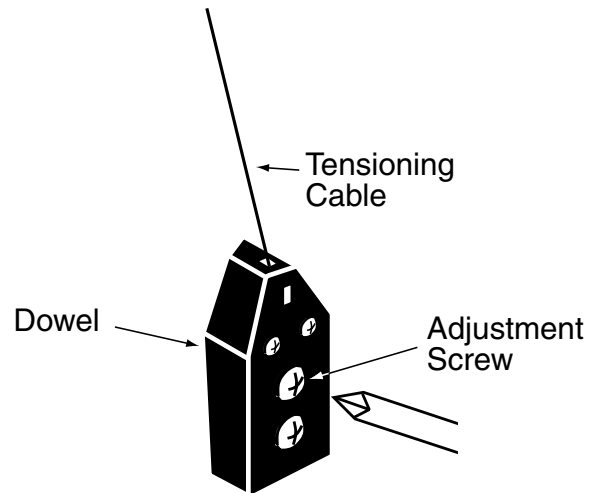

**Wiring Diagrams for Optional Built-in Controls**

**Built-in Low Voltage Control**

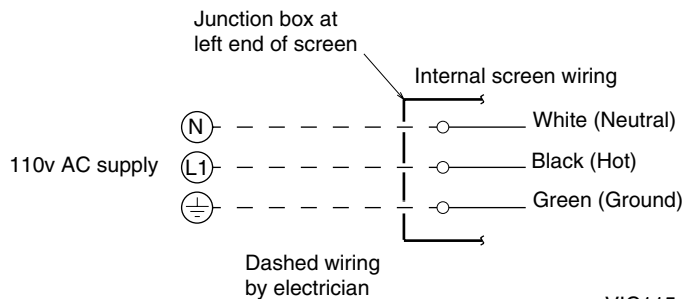

**Built-in Video Interface Control**

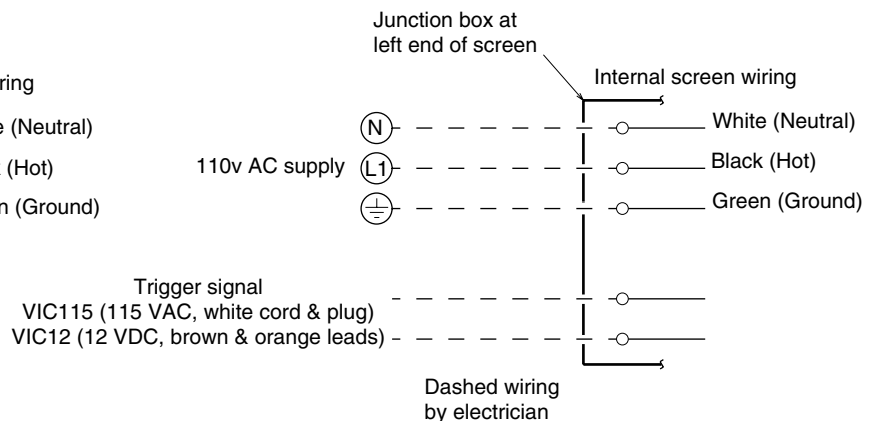

**Case Dimensions**

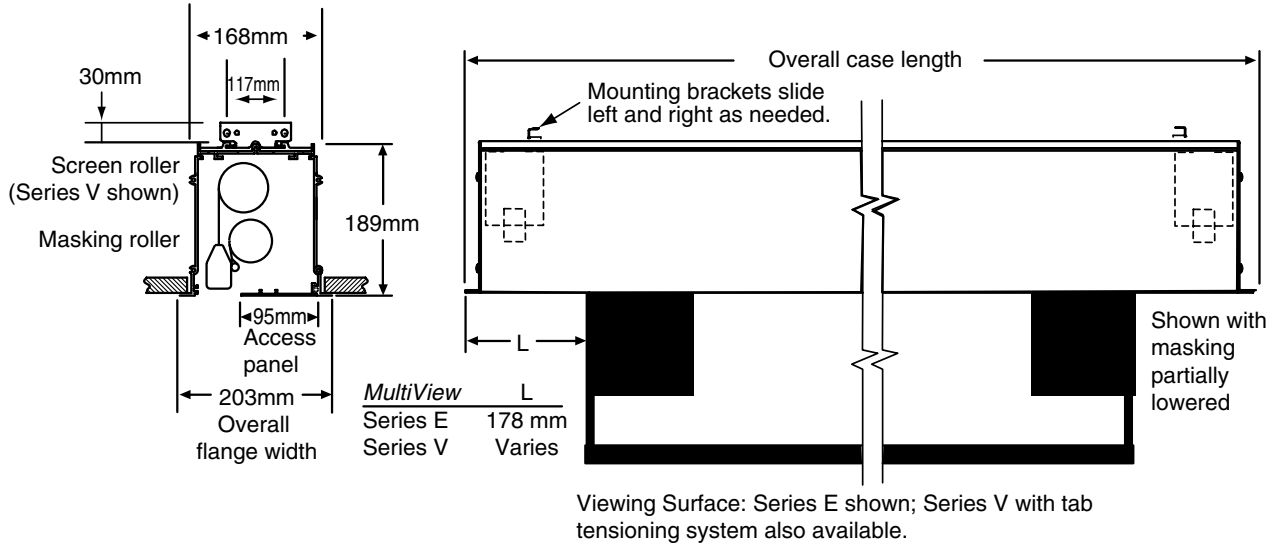

**Wiring Diagram**

**Single Station Control**

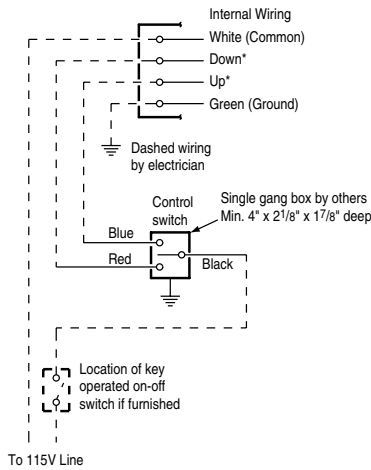

**Multiple Station Control**

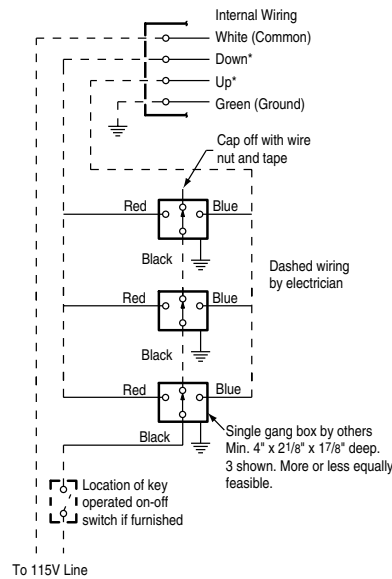

Screen and masking system are independently wired, each using any control offered on the reverse, from a single junction box.

**\*Wire colors:**

	<i>Up</i>	<i>Down</i>
Screen	Red	Black
Masking	Black	Red

**Low Voltage (& Wireless) Control Wiring Diagram**

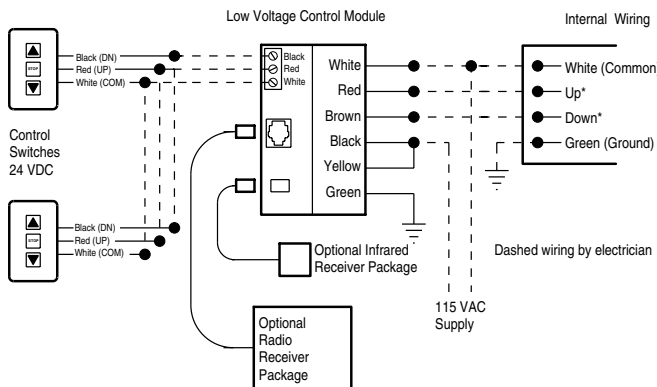

**Access MultiView Control**

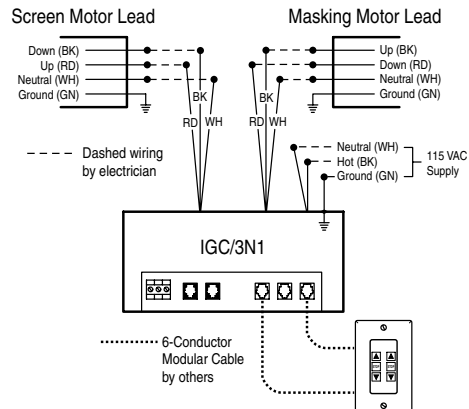

If you encounter any difficulties installing or servicing your Access MultiView screen, call your dealer or Draper, Inc., in Spiceland, Indiana, 765/987-7999, or fax 765/987-1689.