

# Installation/Operating Instructions

## 220V Artisan Series Electric Projection Screen

These Installation/Operating Instructions are available in the official language of the country where you purchase the product. Please contact your distributor to request a copy.

Vous pourriez demander les instructions d'installation et d'opération traduites dans la langue officielle du pays où vous achetez le produit. Veuillez demander à votre distributeur.

Die Gebrauchsanweisung für Installation und Konstruktion sind in der offiziellen Sprache des Landes, indem Sie das Produkt gekauft haben, vorhanden. Fragen Sie die jeweilige Verkaufs-Abteilung.

### Caution

- 1 Read instructions through completely before proceeding.
- 2 Follow instructions carefully. Installation contrary to instructions invalidates warranty.
- 3 Screen should be accessible for complete removal should fabric become damaged or should other service be required.
- 4 Screen should be installed level (using a carpenter's level).
- 5 Nothing should be fastened to screen dowel or viewing surface.
- 6 Operating switch(es) packed separately in screen carton. Do not discard with packing material.
- 7 Screen operates on 220 v., 50 Hz., 1 ph. current.

NOTE: Screen has been thoroughly inspected and tested at factory and found to be operating properly prior to shipment.

### Hanging Screen

#### General

When locating viewing surface and checking clearance for screen's operation, remember surface is centered in case. Take care to install wall/ceiling electrical box and conduit so they will be fully concealed by the screen case after installation. Handle case carefully to protect its finish. Regardless of mounting method, screen should be positively and securely supported so that vibration or even abusive pulling on the viewing surface will not cause case to work loose or fall. Installer must insure that fasteners used are of adequate strength and suitable for the mounting surface chosen.

#### Wall Mounting

Mount 2, 3, or 4 aluminum brackets provided on the wall at desired height, using toggle bolts provided or other appropriate fasteners. Verify that they are in line and level to fully engage matching brackets pre-installed on back of screen case. When screen is set on brackets, pull down gently to ensure that it is snug and secure.

#### Ceiling Mounting

Install through the two 24 mm diameter mounting holes at each end of the screen case, using appropriate fasteners.

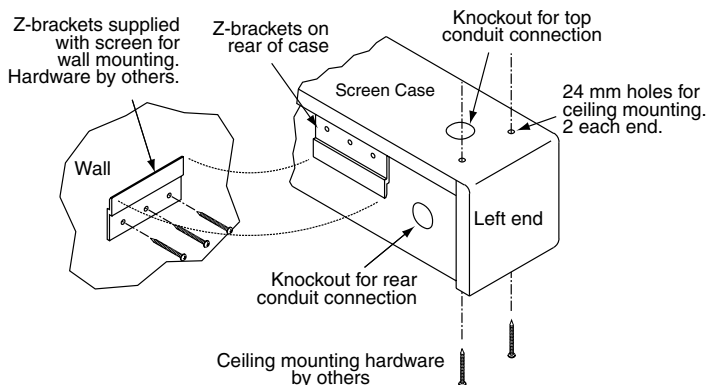

### Electrical Connections

Screen operates on 220 v., 50 Hz., 1 ph. current. Junction box is located inside left endcap and cover plate is secured to endcap with two screws. Junction box

contains terminal strip, per wiring diagram on reverse.

Wall or ceiling electrical box should be installed so as to be fully concealed by screen case after installation. Conduit openings are covered by plastic caps (to be removed for installation). Opening for ceiling mounting is located in top, 73 mm from the end and 64 mm from the back of the case. Opening for wall mounting is in back, 73 mm from the end and 70 mm from the top of the case. Screen is shipped with internal wiring complete and control switch(es) fully boxed. Wire connecting screen to switch(es) and switch(es) to power supply should be furnished by installer. Connections should be made in accordance with wiring diagram supplied, and wiring should comply with national and local electrical codes.

**All operating switches should be "Off" before power is connected.**

### Operation

**Series E:** Before operating screen remove tape securing fabric and dowel to roller. If viewing surface hangs out of case 20 to 23 cm, tape has probably been broken by rough handling in shipment, allowing surface to "unwrap" one turn about the roller. Manually wrap the fabric back around the roller without turning the roller itself.

**Series V:** Important Instructions—The shipping support brackets must be removed from each end of dowel during initial operation before screen is operated in UP direction. After screen is installed, run viewing surface DOWN to access screws that hold brackets to dowel. Loosen hex head screw, remove bracket and retighten screw at each end of dowel. Cycle viewing surface down and up several times to confirm satisfactory operation. If viewing surface does not operate properly, turn power off and check electrical connections.

**220V Single Station Control**—3-position up-off-down switch permits operation to be stopped at any point. Factory adjusted limit switches automatically stop screen when fully down or fully up.

**220V Multiple Station Control (Not CE approved)**—Switches are similar in appearance to 220V Single Station Control. Screen stops when switch is released and may be restarted in either direction. Factory adjusted limit switches stop screen automatically when fully up or fully down.

**24V Control**—Three-button up-stop-down switch(es) stop at any point desired, operate in any sequence. Factory adjusted limit switches automatically stop screen when fully up or fully down. Installer should incorporate an all-pole disconnect in the fixed wiring.

**Key Operated Switching (Not CE approved)**—Two kinds of key-operated switches are optionally available with this unit. ① The key-operated power supply switch controls power to the screen and switches. When it is "off", the switches will not operate screen. Key may be removed from the switch in either "on" or "off" position. ② A three-position key switch permits the screen to be operated directly by key. In this case, the screen's operator must always have a key.

### Adjustments

Screen has been factory set and should not normally require further adjustment. However, if you desire to change the "up" and "down" stopping positions, proceed as follows:

**CAUTION:** Be sure all switches are in "off" position before adjusting limit switches. Always be prepared to shut screen off manually when new adjustment is being tested. Screen may be severely damaged if viewing surface is allowed to run too far up or too far down.

**Adjusting "fully up" position** — "Up" stopping position may be adjusted by turning the yellow limit switch adjustment socket. The yellow socket is located on left end of screen roller and is accessible to a screwdriver/Allen wrench (4mm or 5/32"). Turning the socket counterclockwise will allow the viewing surface to retract farther into the case. Turning it clockwise will cause the surface to stop farther out of the case. One full revolution of the socket will alter the stopping position of the viewing surface by approximately 38 mm (1 1/2").

**Adjusting "fully down" position** — "Down" stopping position may be adjusted by turning the white limit switch adjustment socket. The white socket is located on the left end of screen roller and is accessible to a screwdriver/Allen wrench (4mm or 5/32"). Turning the socket counterclockwise will allow the viewing surface to run farther down. Turning it clockwise will shorten the viewing surface, causing it to stop in a less extended position. At no time should viewing surface be unrolled enough to expose any part of screen roller.

# DRAPER

411 S. Pearl St., Spiceland, IN 47385 USA ■ 765-987-7999 ■ fax 765-987-1689

e-mail draper@draperinc.com ■ www.draperinc.com

Copyright ©2003 Draper Inc.

Form ArtisanE&V220V\_Inst03

Printed in U.S.A.

If you encounter any difficulties installing or servicing your Artisan Series screen, call your dealer or Draper, Inc. Spiceland, Indiana, U.S.A., telephone (765) 987-7999, fax (765) 987-1689, or email draper@draperinc.com.

## Tab-Tension Adjustment Procedure

Draper's Tab-Tensioning System is factory-set, and under normal circumstances will not require field adjustment. If, however, you notice wrinkles, waves or other indications that the tensioning cables need to be adjusted, follow the procedure below.

- ① Determine which side requires adjustment.
- ② Secure dowel with one hand.

**Caution: Do not touch or bend surface.**

- ③ Using Phillips-head screwdriver, depress spring-loaded adjustment screw and slowly turn clockwise to tighten tension, or counterclockwise to loosen tension. The screw adjusts in 1/4 turn increments. Adjust only **one increment (1/4 turn) at a time.**

- ④ If problem is not corrected, leave screen in position for 24 hours to allow surface material to stretch into position.

- ⑤ If problem still is not corrected, repeat steps 2 and 3.

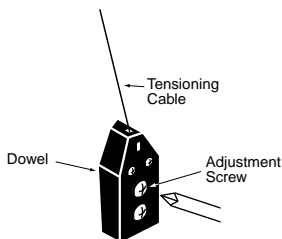

## Case Dimensions

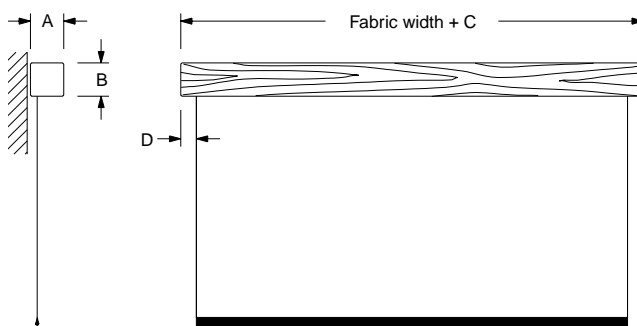

	A	B*	C	D
Series E	127 mm	133 mm	305 mm	152 mm
Series V	152 mm	162 mm	varies	varies

\*Add 29 mm to height if case is to be bevel style.

## Wiring Diagrams

### Single Station Control CE Approved

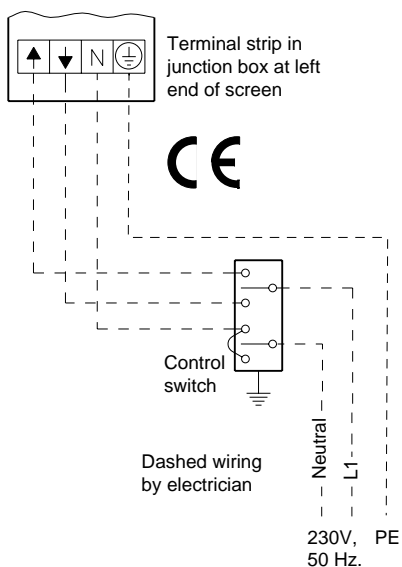

### Multiple Station Control Not CE Approved

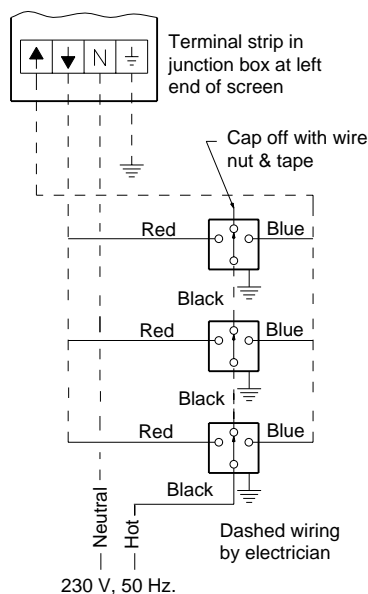

### Low Voltage (& Wireless) Control Wiring Diagram CE Approved

